

esuno

MANUAL / HANDLEIDING / MODE D'EMPLOI / ANLEITUNG / MANUAL

EN	4 - 17
Important information	4
Preparation	5 - 9
Step-by-step plan	10 - 17
Storage & cleaning	17
Garantie & repairs	17
NL	18 - 31
Belangrijke informatie	18
Vorbereiding	19 - 23
Stappenplan	24 - 31
Opslag & reiniging	31
Garantie & herstellingen	31
FR	32 - 39
Informations importantes	32
Préparation	33 - 37
Plan par étapes	38 - 45
Stockage & nettoyage	45
Garantie & réparations	45
DE	46 - 39
Wichtige Informationen	46
Vorbereitung	47 - 51
Schritt für Schritt	52 - 59
Lagerung & Reinigung	59
Garantie & Reparaturen	59
ES	60 - 73
Información importante	60
Preparación	61 - 65
Esquema paso a paso	66 - 73
Limpieza y almacenamiento	73
Garantía y reparaciones	73

Read the assembly manual thoroughly before use and keep it in a safe place, so you can consult it later if necessary. You can also download the manual from our website.

Throughout the step-by-step plan, we regularly mention “- 10 m” and “+ 10 m”. This concerns the width of the tent. “- 10 m” applies to 5 x 6.5 m, 6.5 x 6.5 m, 10 x 6.5 m, 10 x 8.5 m en 12.5 x 8.5 m, “+ 10 m” applies to 10.5 x 10 m, 12.5 x 10 m, 15 x 10 m, 17 x 10 m, 21.5 x 10 m, 20 x 15 m.

SAFETY AND DURABILITY

- » Tents are intended as temporary shelter.
- » The person who erects the tent is responsible for its correct anchoring and therefore for its safety. Check the anchoring of the tent to the ground regularly to ensure the safety of the tent, to prevent damage to the tent and to protect other users.
- » In the event of severe weather conditions, keep an eye on the weather forecasts and provide temporary extra anchoring for the tent or dismantle the tent. In the event of stormy weather you must take down the tent to prevent permanent damage.
- » With the use of an appropriate heating appliance, a distance of at least 1.2 m from the tent canvas must be maintained. Open fires and heating appliances with an open flame may not be used under any circumstances.
- » In the event of snowfall, you must regularly remove the snow from the tent canvas. This also applies to heavy rainfall and loading of the tent canvas with other materials. If you cannot free the canvas from snow accumulation you must store the tent dry. In the event of snowfall, you can also heat the tent to 2 degrees so that the snow melts and the tent canvas flows.
- » You can use the tent in light frost. The tent canvases must however be kept sufficiently long at a temperature of at least 10 °C and must be folded at the same or higher temperature. Otherwise the canvases might split in the places they are folded.
- » Only use materials that are supplied with the tent. Make sure that the ground underneath is suitable for the purpose for which you wish to use the tent.
- » Check the tension on the tent regularly and adjust it if necessary.

1.1: PREPARING THE ALUMINIUM POLES

If you are assembling the stretch tent using wooden poles, you can skip this step.

You have poles of 110 cm and 50 cm in length. You can connect these poles using a coupling piece to achieve the desired height.

Only for - 10 m: Later on the side clamps will slide into the connected poles as shown below (see page ##).

For + 10 m: Go to step 1.1.1

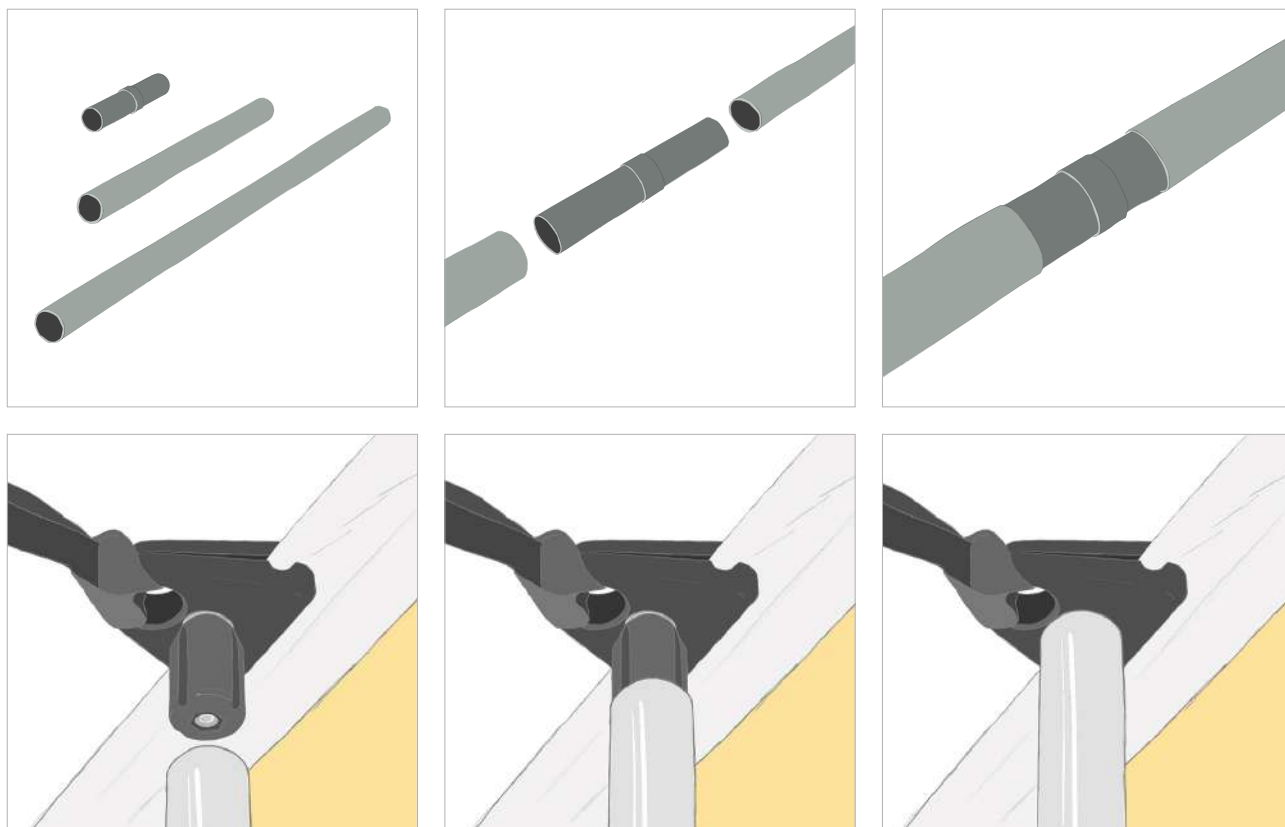

Use the same method to combine poles to the required length to create one or more centre poles. Each time, mount a pole cap (XL or small) on the top.

1.1.1: PREPARING THE STURDY ALUMINIUM POLES (Ø 60 MM): CARABINER + EYEBOLT & PRE-CUT THREADED ROD

+ 10 m: The pole sets for these tents by default consist of sturdy poles with a diameter of 60 mm.

-10 m: The sturdy aluminium poles are also optionally available for these tents. In that case, they replace the standard poles with a diameter of 40 mm.

You can also place the poles outside the canvas and bring the canvas to tension using a carabiner which clicks fast in the side clamp.

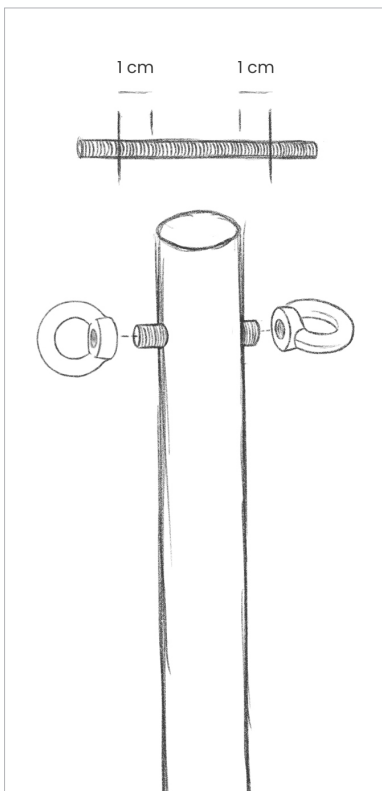

- » Attach the threaded rod in the opening and tighten the eyebolt at both ends.
- » Later on the pole will be placed so that the (opening with the) eyebolts is/are perpendicular on the canvas (see page ##).
- » Connect the side clamp with one eyebolt using a carabiner.
- » Bring the canvas to tension by fitting a carabiner with tension strap to the eyebolt on the other side of the pole which you pull toward the anchoring point.
- » The clamps on the left and right of the pole are also fitted with a carabiner and pulled individually to the anchoring point.

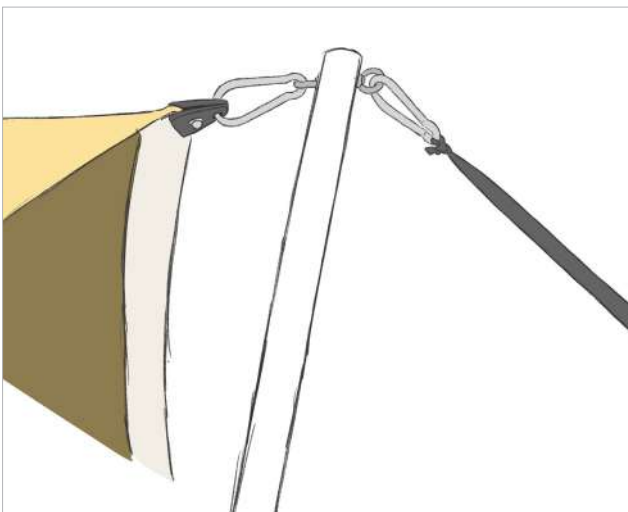

Carabiner on corner or side pole

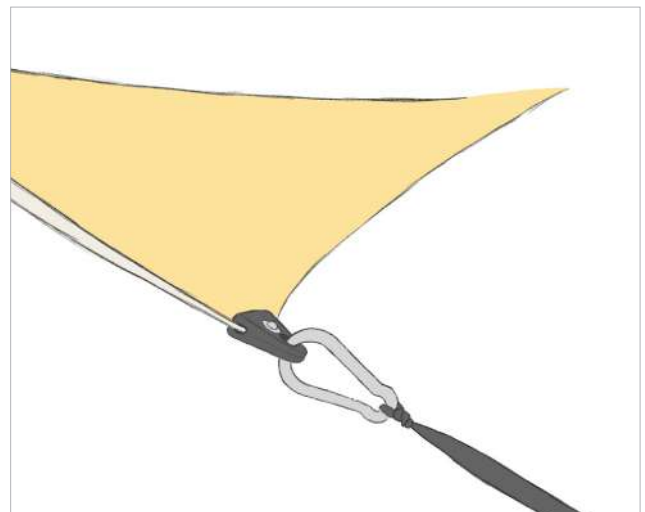

Carabiner on side clamp without pole

1.2: PREPARING THE WOODEN POLES

If you are assembling the stretch tent using aluminium poles, you can skip this step.

Each pole to which corner or side clamps are attached must be pre-drilled. To do this, use a 16 mm drill bit and drill a 7 cm deep hole as centrally as possible.

Note: For tents with a width of 10 m or more (+ 10 m) we recommend the use of carabiners (see step 1.2.1.). This way, the fabric gets more space to move and the risk of damage to the fabric with windy weather is reduced.

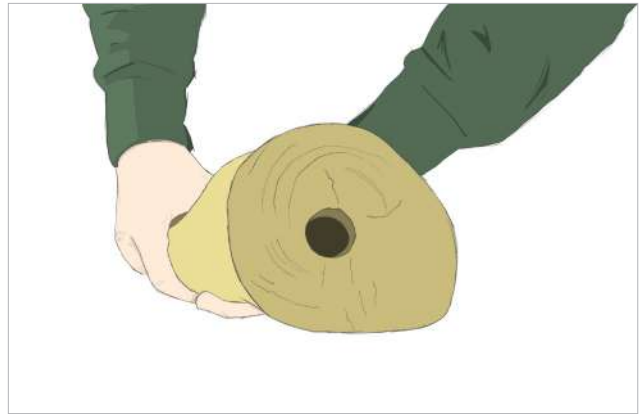
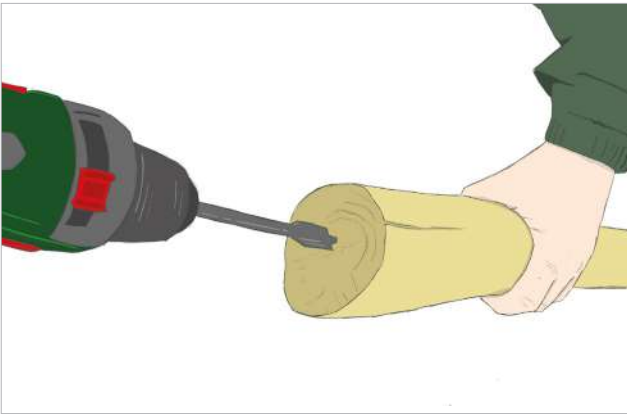

» Remove the hand clamp from the side clamps.



» Use the oblong nut in the hand clamp to re-tighten the side clamps. You can use the hand clamp and the supplied hexagonal wrench to tighten the nut. The hand clamp is not used in the side clamps if you are using wooden poles.

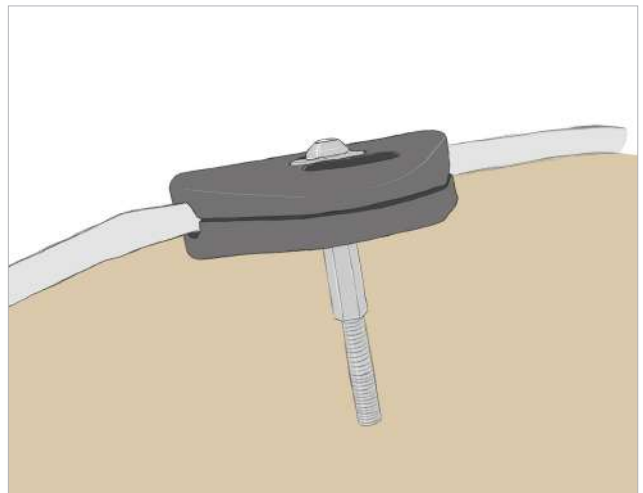

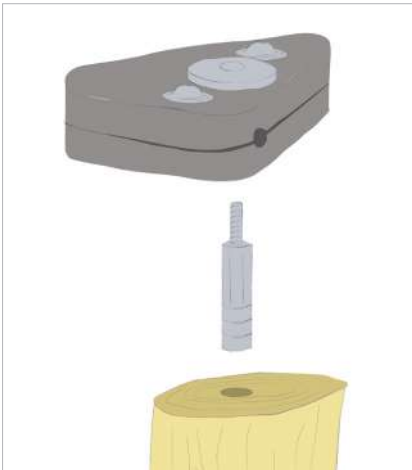

Corner clamp: Screw the two nuts and the connector nut on the bolt up to the head of the bolt. Then screw the bolt on the corner clamp until it's firmly secured.

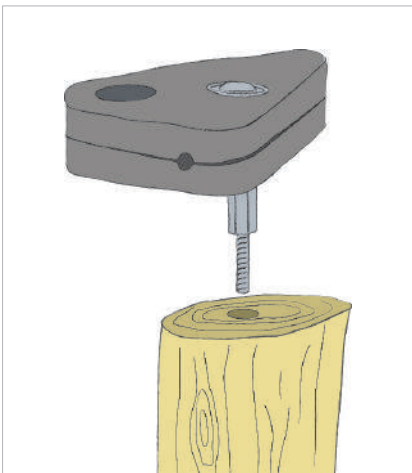

Side clamp: The supplied cap nuts go onto the long bolt of the side clamps which are attached to a wooden pole. If everything has been assembled correctly, the assembly will fit perfectly in the pre-drilled 16 mm hole.

1.2.1: POLE CAP WITH ADAPTOR FOR WOODEN POLES

Screw the adaptor for wooden poles to the top of the centre using a screw of around 10 cm. Now slide the supplied pole caps (small or XL) over the wooden adaptor.

When the poles have plates at both ends, you can fix the adaptor by screwing through the opening in the plate. You don't have to remove the plate.

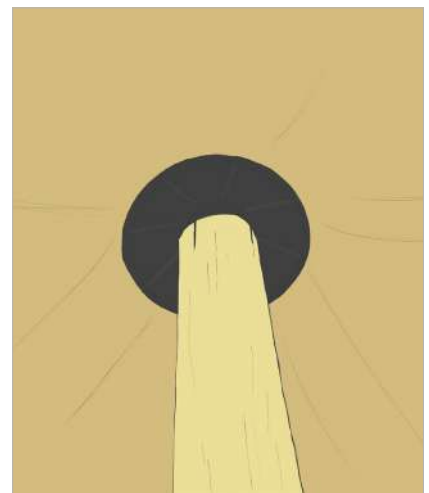
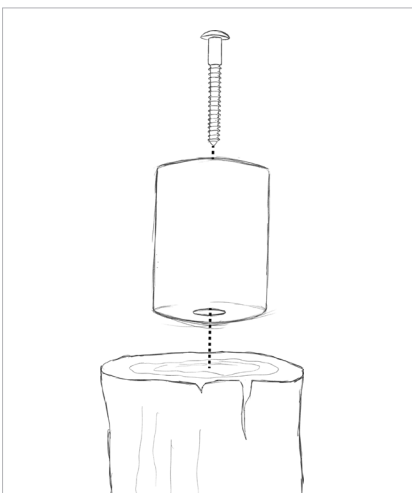

1.2.2: RECOMMENDED FOR WOODEN POLES: CARABINER + EYEBOLT & THREADED ROD

You can also place the poles outside the canvas and bring the canvas to tension using a carabiner which clicks fast in the side and corner clamp.

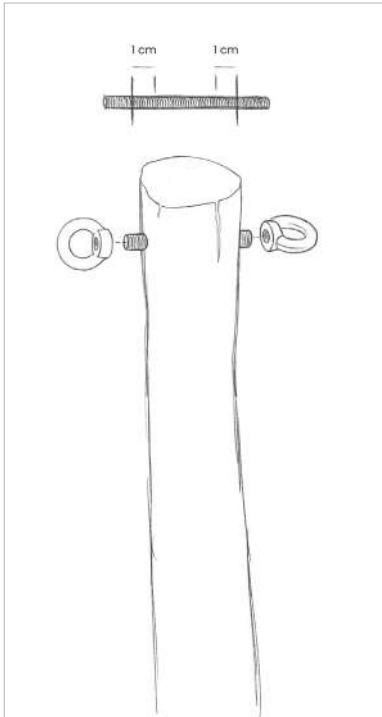

- » Drill a horizontal opening (\varnothing 10 mm) on the top of the pole. Do this five to ten cm from the top of the pole.
- » Cut the threaded rod to the desired length. Create a protrusion of 1 cm threaded rod on both sides of the pole.
- » Attach the threaded rod in the opening and tighten the eyebolt at both ends.
- » Later on the pole will be placed so that the (opening with the) eyebolts is/are perpendicular on the canvas (see page ##).
- » Connect the side clamp with one eyebolt using a carabiner.
- » Bring the canvas to tension by fitting a carabiner with tension strap to the eyebolt on the other side of the pole which you pull toward the anchoring point.
- » The clamps on the left and right of the pole are also fitted with a carabiner and pulled individually to the anchoring point.

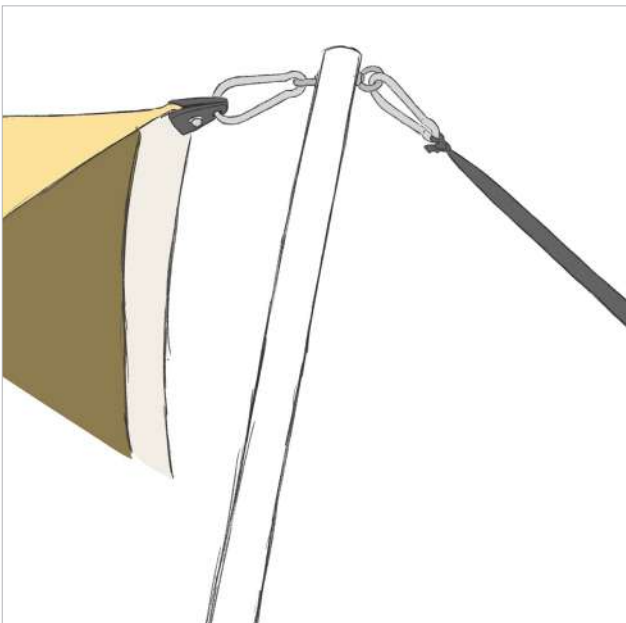

Carabiner on corner or side pole

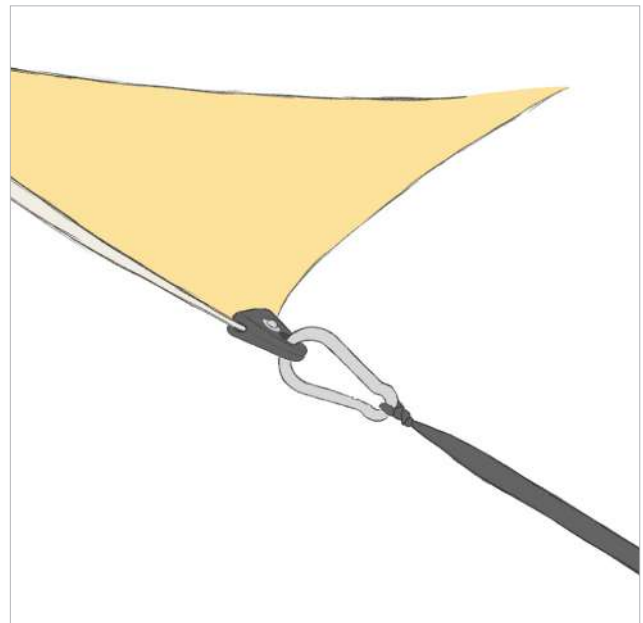

Carabiner on side clamp without pole

3. STEP-BY-STEP PLAN / SAFARI

The following step-by-step plan outlines how to assemble the tent in the safari design. Remove the tent from the box supplied along with all of the parts. It's a good idea to keep the box for easy storage.



STEP 1: OPEN TENT CANVAS

Lay the stretch canvas open in the location where the tent is to be assembled. Make sure that the correct side is on top.

TIP: Lay the stretch tent on a groundsheet to avoid marks on the inside. This groundsheet is not supplied by Bonga.

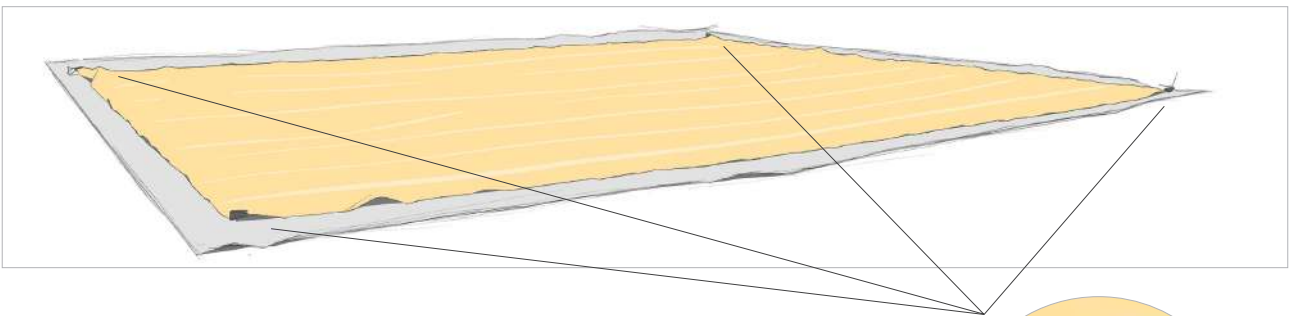

There are already four corner clamps attached to the corners of the stretch tent. These may not be removed or replaced. Check regularly that the corner clamp is under sufficient tension.

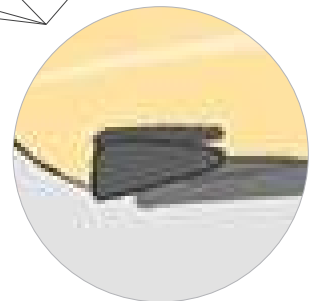

Only for - 10 m: Use of corner clamp on aluminium pole (with hand clamp):

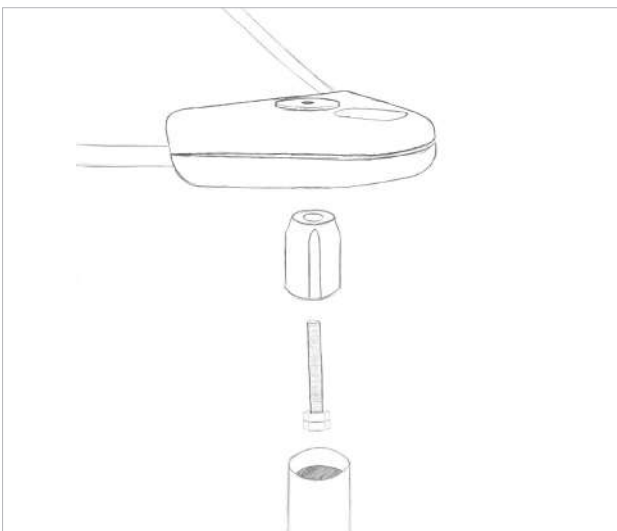

Only for - 10 m: Use of corner clamp on wooden pole (without hand clamp):



STEP 2: ASSEMBLING AND ATTACHING SIDE CLAMPS

The edge of the Bonga stretch tent has reinforced zones every metre. Only place the side clamps on these reinforced zones! You can see and feel the reinforced zones when you look at the tent canvas closely. This is very important to prevent damage to the canvas edge.

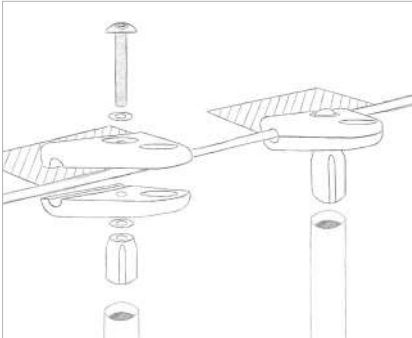
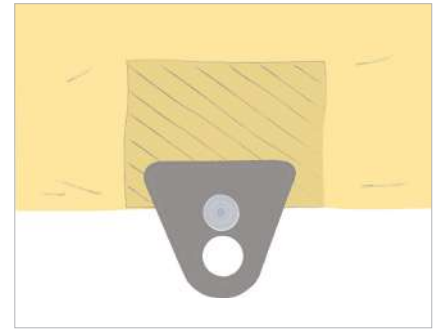

Only for - 10 m: Side clamps under which an **aluminium pole** is standing slide easily into the pole and are fixed in place using the hand clamp (see step 1.1).

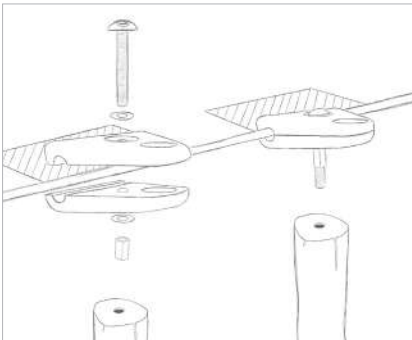

For side clamps under which a **wooden pole** is standing, remove the hand clamp and slide the screw into the pre-drilled holes. The instructions on how to do this can be found in step 6.

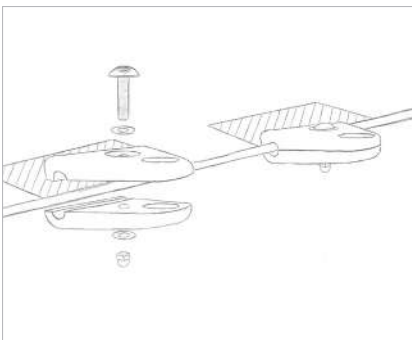

The side clamps under which **no pole** will be installed or side clamps **in combination with carabiners**, can be fitted with a hexagon socket bucket head screw (35 mm) with cap nut which is supplied in the zip bag. This ensures a neater appearance without hand clamps (see step 1.1.1 for aluminium poles and step 1.2.2 for wooden poles).

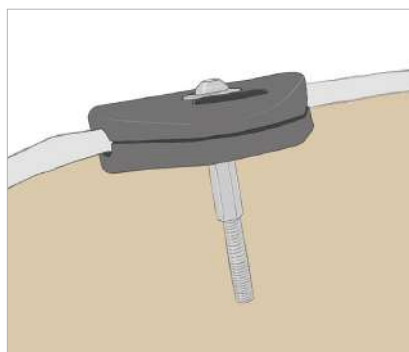

Now go to where the reinforced zones are attached on the assembly plan and fix the side clamps in the locations indicated. Always tighten the side clamps firmly. To do this you can use the hexagonal wrench supplied in the zip bag.

STEP 3.1: ATTACHING TENSION STRAPS

Attach the supplied tension straps to the corner and side clamps as follows.

- » Make a loop at the end of the tension strap.
- » Pull the loop through the hole in the clamp.
- » Pull both ends of the tension strap through the loop.

There is one tension strap on each side clamp. There are two tension straps on each corner clamp.

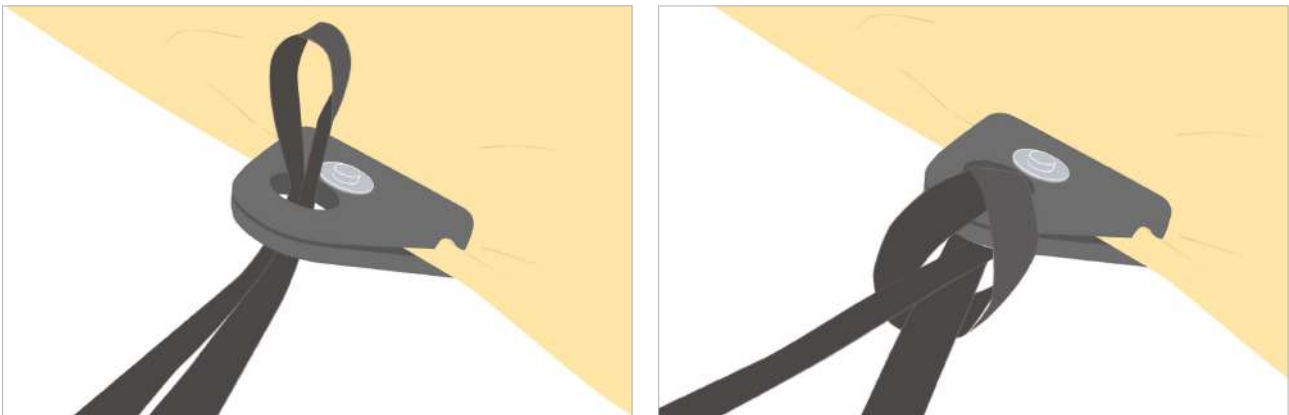

STEP 3.2 - ALTERNATIVE WITH RATCHET: ATTACHING ROPES AND RATCHETS

Sides

Contents of pre-made set:

- » 5 m long rope with 3 knots (2 on the ends, 1 in the middle)
 - » 5 m long rope with one not at the end, ratchet at the other end
 - » 3 m long rope with one not at the end, ratchet at the other end
- » Put a carabiner through the knots at both ends of the 5 m long rope with three knots.
 - » The side clamps on the canvas edge are always in groups of three. Hook the two carabiners with the 5 m long rope onto the two outer side clamps (safari setup).
 - » Put a carabiner through the knot at the end of the 3 m long rope and hook the carabiner onto the knot in the middle of the 5 m long rope that was already attached to the two outer side clamps.
 - » Put a carabiner through the 5 m long rope with one knot and hook the carabiner onto one of the eye bolts on the side pole that will be placed in that spot.
 - » Connect the middle side clamp to the eye bolt on the other side of the side pole using a carabiner.

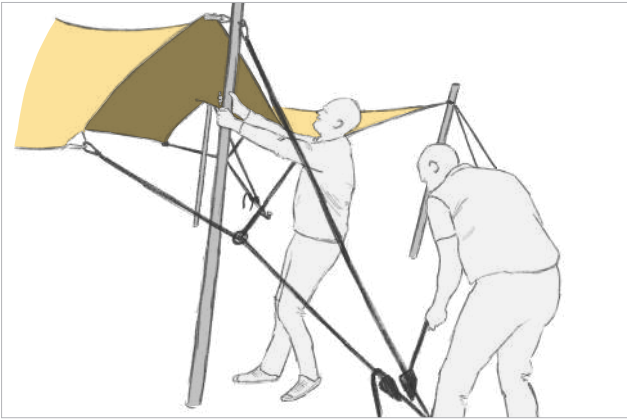

This is what the build-up of the ropes with ratchets (with the tent under tension) looks like.

Corners

Contents of pre-made set:

- » 2 x 5 m long rope with one not at the end, ratchet at the other end
- » Put a carabiner through the knot in the two 5 m long ropes and hook both carabiners onto the same eye bolt on the corner pole that will be placed in that spot.
- » Connect the corner clamp to the eye bolt on the other side of the corner pole using a carabiner.

STAP 4.1: HARINGEN

De spanriemen worden vastgelegd met haringen in de grond. De haringen zijn geschikt voor een zachte ondergrond. Er is keuze tussen haringen van verschillende lengte en dikte.

Let er zeker op dat je bij een harde ondergrond de juiste haringen of andere verankeringmiddelen (oogbouten, haken, betonblokken... - niet inbegrepen) gebruikt.

Neem bij het plaatsen van de haringen de volgende aspecten in acht:

- » Plaats de haring op ongeveer 2 m van het tentzeil.
- » Sla de haring onder een hoek van 70° in de grond. Sla de haring in de richting van de tent met de haringkop weg van de tent.

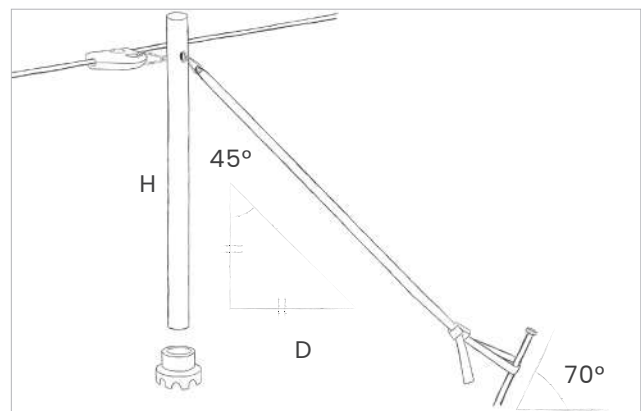
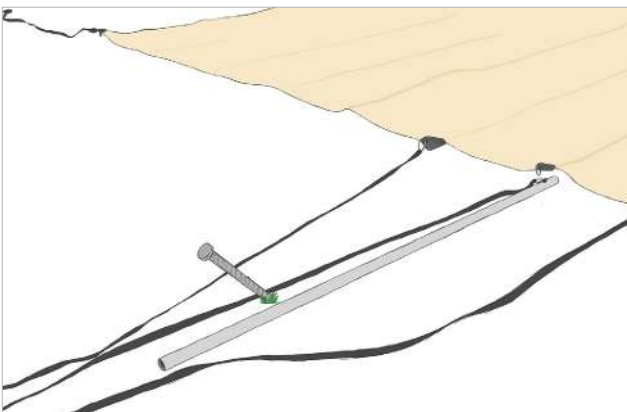

When the pegs are in the ground, knot the short tension strap with the tension clamp around the peg. Thread the long end of the tension strap which is hanging from the side clamp through the small clamp on the peg.



Let the tension strap lie loose on the ground for a moment and don't increase the tension on it yet. The tension straps may only be put under tension once the poles have been erected underneath the tent.

STEP 4.2 - ALTERNATIVE WITH RATCHET: PEGS

The ropes are fixed using pegs in the ground. The pegs are suitable for soft ground. You can choose from pegs of different lengths and thicknesses.

Make sure that if the ground is hard you use the right pegs or other anchoring methods (eyebolts, hooks, concrete blocks etc... - not included).

Consider the following aspects when placing the pegs::

- > Place the peg at a distance of about 2 m from the tent fabric.
- > Place the peg in the ground at an angle of 70°. Place the peg in the direction of the tent with the peg head facing away from the tent.

When the peg is in the ground, tie the short loop of rope with the ratchet to the peg.

Let the rope lie loose on the ground for a moment and don't increase the tension on it yet. The rope may only be put under tension once the poles have been erected underneath the tent.

STEP 5: ERECTING THE CORNER AND SIDE POLES

- » Erect the four corner poles one by one. Always start from the inside out beneath the canvas so that the poles are erect and with aluminium poles always use a pole base to keep the pole neatly in place.
- » Tighten the tension straps of the corner poles slightly so that the pole remains upright, but do not tighten them fully at this stage.
- » Erect the side poles of two opposite sides. It is recommended that the sides facing the wind direction be erected first.
- » Tighten the tension straps slightly until the tent canvas floats above the ground, but do not tighten the tent to full tension yet.

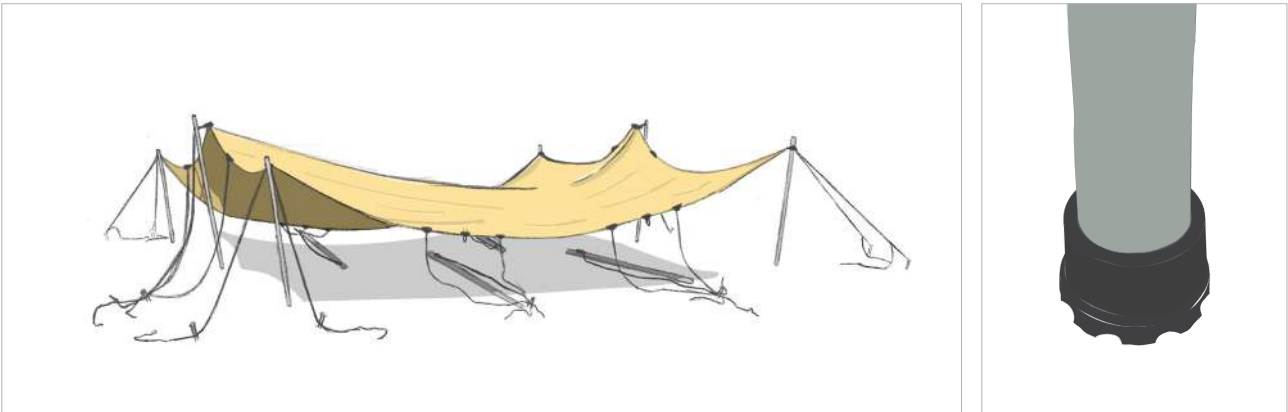

» Now erect the side poles on the two other opposite sides.

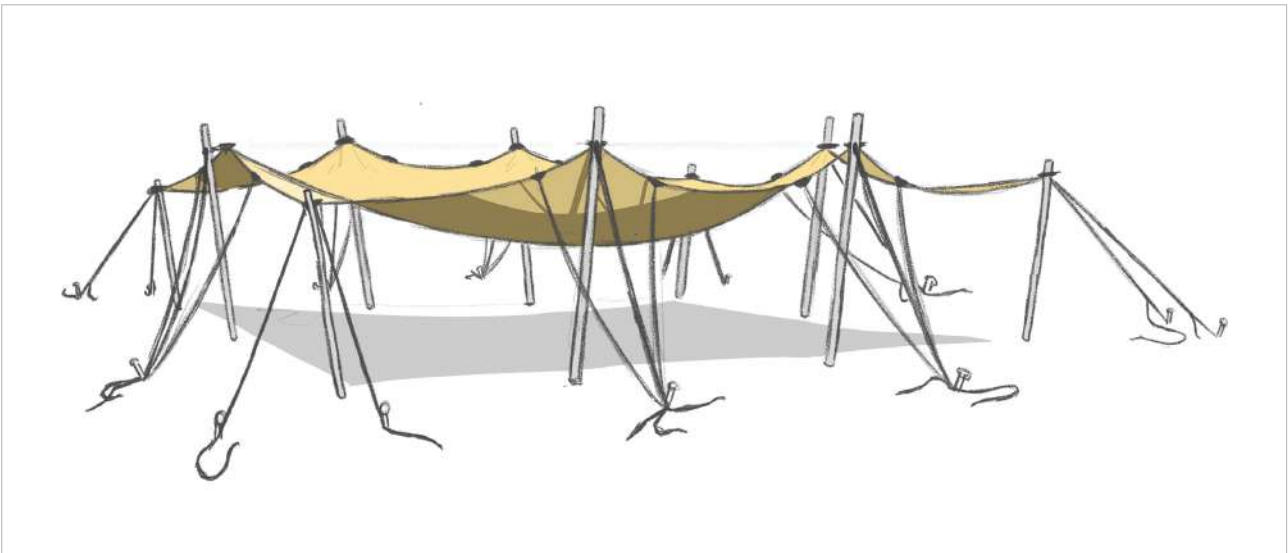

The side and corner poles are never fully perpendicular to the ground but are always slanted slightly outwards.

STEP 6: ERECTING THE CENTRE POLE WITH POLE CAP

Thanks to the large surface area of the pole cap (XL), the pressure on the canvas is better distributed and there are fewer remaining imprints of the pole cap in the canvas after use.

- » Please ensure that all of the desired corner and side poles are set up.
- » Raise the centre pole via the side of the tent until it stands upright in the centre. Take care never to use the centre poles without a pole cap to prevent tears. It's best to push the pole upwards in one smooth movement, using two people, whereby one person indicates directions and the other person makes any necessary adjustments. If you are having difficulty getting the centre pole fully upright, loosen the tension straps slightly.

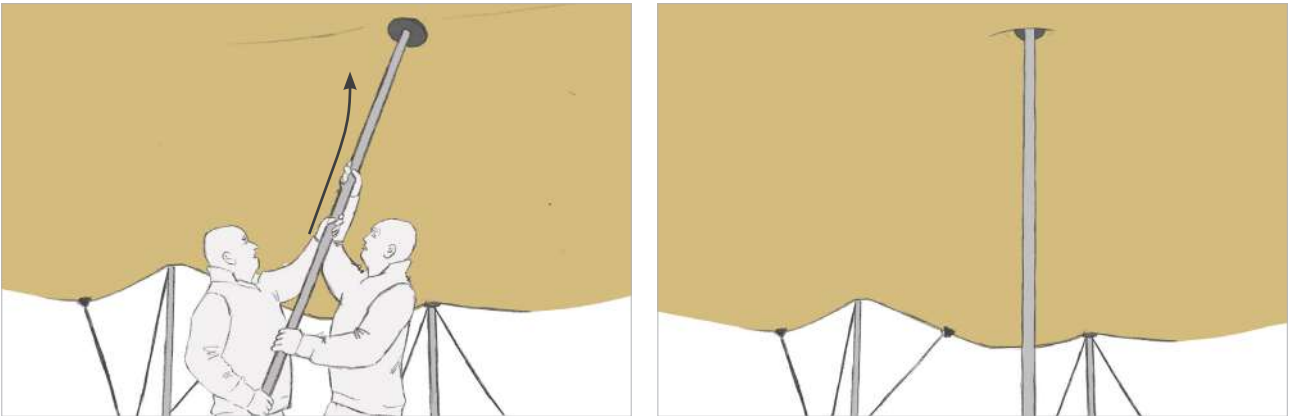

TIP - For tents starting from 10 x 10 m it is not easy to place the centre pole in the desired position right away. It's best to initially place one pole in a random location so that the canvas is kept floating in order for the poles to be positioned in the correct locations. The first pole that you have used as a support is then finally the last to be placed in the correct position.

STEP 7: PUT THE TENT UNDER TENSION

Once all of the poles are upright, put the stretch canvas under the correct tension by tightening the tension straps.

It's best to tighten the tension straps evenly and increase the tension gradually. For example, you can go around the tent several times until you achieve the correct tension.

For each pole, it's best to start with the tension strap that comes out from the pole. Tighten the tension strap which is attached to the pole more easily by using a second person who pulls the top of the pole outwards.

To bring the side clamps under tension smoothly, one person pulls the pole towards themselves, while the other person tensions the strap.

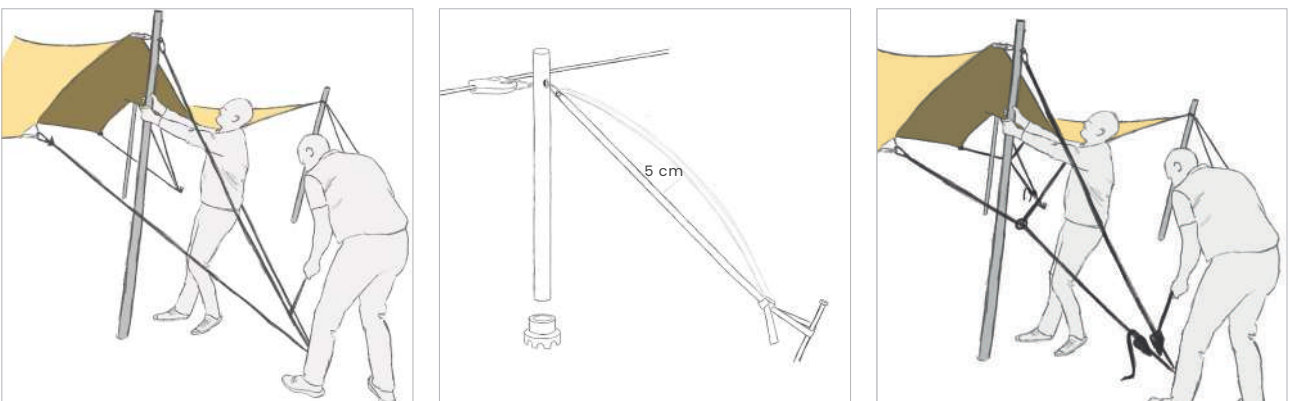

TIP - The tension strap can move back and forth ten centimetres or so for the perfect tension.

TIP - Don't overtighten the tension straps as this can damage your tent. Never use a ratchet for this.

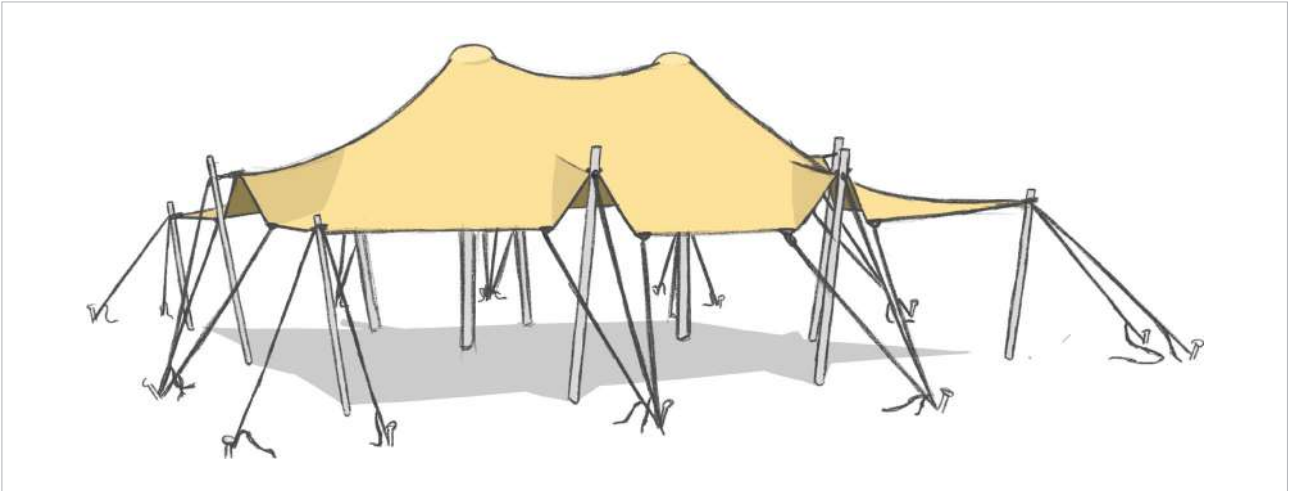

Carry out the following checks once the tent has been standing for half a day or so and carry them out regularly for long-term assemblies.

- » Are the pegs still anchored well?
- » Are the tension straps still under sufficient tension?
- » Have any water pockets formed on top of the tent?

TAKING THE TENT DOWN

Taking the tent down goes smoothest if you pay attention to the following points.

- » Take the tent down during dry weather and put a groundsheet down to protect the canvas against dirt.
- » Loosen the tension straps and take down the poles. Begin with the centre poles and finish with the side and corner poles.

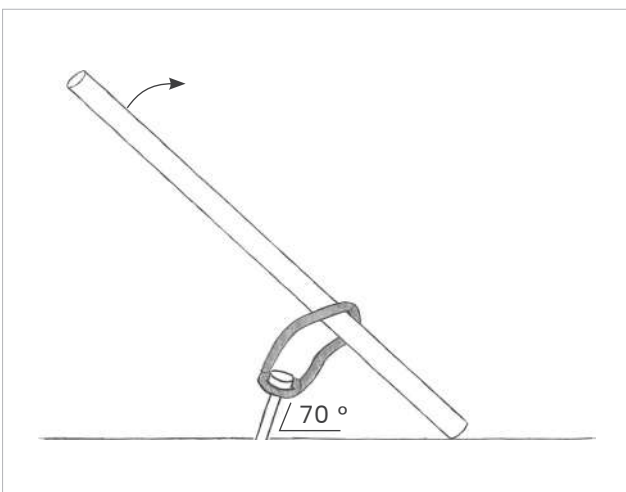

TIP - to remove the pegs more easily

- » Take a pole of around two metres and tie a loop around the pole.
- » Attach the loop to the peg and pull on the top of the pole.

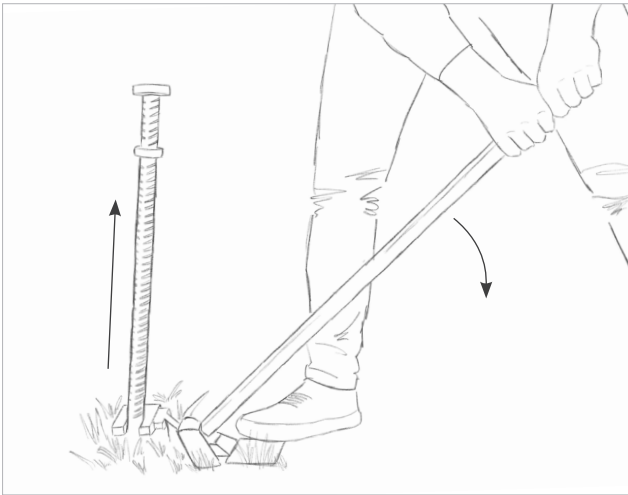

TIP - If you are using longer pegs that are difficult to remove from the ground, you can always use a peg lifter.

4. STORAGE AND CLEANING

- » Do not use aggressive cleaning materials to clean the tent canvases. To clean the canvas use only a mild soap solution (For example water and Dreft).
- » Do not fold the tent or pack it away when it is damp. First let the tent canvases dry fully and keep the tent in a dry storage place.
- » Handle all of the tent's components carefully. When taking the tent down, use the packing list and check that the tent is complete before you store it. This will prevent problems the next time you want to put the tent up.
- » Store the tent in a dry location and don't place sharp objects on top of the tent. The clamps and tension straps can be left attached to the canvas. This will make it quicker to put the tent up next time.
- » If wear and tear occurs as a result of assembling the tent and taking it down many times, such as small tears, you can use the small adhesive patch supplied in the zip bag to fix them.

5. GUARANTEE & REPAIRS

We provide customers with a guarantee against concealed faults in the products for two years. We do not provide any guarantee against concealed faults in the products after this time. User damage caused by non-compliance with the instructions will not be covered under the guarantee. For further support please contact your distributor.

Bonga stretch tents offer a repair service and supply repair kits for carrying out minor repairs. In the event of repairs, the box supplied can be used to return the tent to us.

bonga

Europalaan 83
9800 Deinze

sales@bongastretchtent.com

esunog

PARTS / ONDERDELEN / COMPOSANTS
TEILE / PARTES

10 M X 10,5 M

EN 4 - 5

Parts 4
Pole sets 5

NL 6 - 7

Onderdelen 6
Palensets 7

FR 8 - 9

Composants 8
Kit de pole 9

DE 10 - 11

Teile 10
Pfahlsets 11

ES 12 - 13

Partes 12
Postes 13

To begin with, check that all of the parts are complete. Depending on which poles you are using and which design you have chosen, you may need certain accessories. Please find below a list of all the accessories supplied with your Bonga tent:

INCLUDED WITH THE TENT

NR.	DESCRIPTION	QUANTITY
1	Tent canvas	1
2	Side clamps + hand clamp	24
3	Corner clamps	4
4	Hand clamp (in zip bag #1)	12
5	Pole cap small	3
6	Pole cap XL	3
7	Wooden adaptor (only required for wooden poles)	6
8	Zip bags *	3

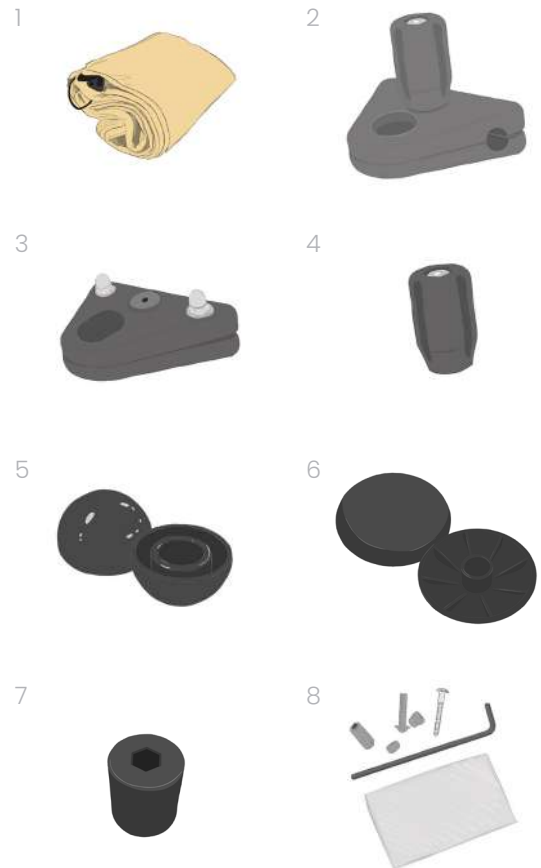

OPTIONAL: INSTALLATION WITH CARABINERS

NR.	DESCRIPTION	QUANTITY
9 a	Screw thread per metre	2
9 b	Eye nut	24
9 c	Carabiner	44

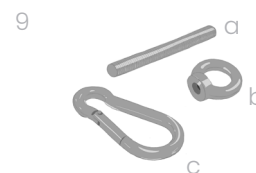

*Zip bag #1 contains: hex bolt M8 x 60 (4 x), nut M8 (8 x), connector nut M8 for use with wooden poles (4 x), hand clamp (12 x) - Zip bag #2 contains: flange screw with socket head M8 x 35 (24 x), cap nut (32 x), tear aid patch (1 x), 5 mm hexagonal wrench (1 x), wood screw (6 x) - Zip bag #3 contains: connector nut M8 (12 x), flange screw M8 x 80 (12 x), washer M8 (64 x)

STURDY ALUMINIUM POLE SET

If you have chosen the aluminium poles, your pole set will consist of the following parts:

N°	DESCRIPTION	QUANTITÉ
1	Aluminium pole 110 cm (Ø 60 mm) pre-drilled for use with eyebolt and threaded rod	12
2	Aluminium pole 110 cm (Ø 60 mm)	20
3	Aluminium pole 50 cm (Ø 60 mm)	8
4	Aluminium coupling piece (Ø 60 mm)	26
5	Pole foot	14
6 a	Pre-cut screw thread Ø 10 mm	12
6 b	Eye nut	24
6 c	Carabiner	44
7	Pole cap for pre-drilled pole	12



bonga

Europalaan 83
9800 Deinze

sales@bongastretchtent.com

esunog

BUILD PLAN / BOUWPLAN / PLAN DE MONTAGE
BAUPLAN / PLANO DE CONSTRUCCIÓN

10 M X 10,5 M

EN	4 - 5
Build plan	4
Set-up options	5
NL	6 - 7
Bouwplan	6
Alternatieve opstelling	7
FR	8 - 9
Plan de montage	8
Configuration	9
DE	10 - 11
Bauplan	10
Aufbauoptionen	11
ES	12 - 13
Plano de construcción	12
Configuración alternativa	13

BUILD PLAN / 10 M X 10,5 M

Various designs are possible with the Bonga stretch tents, but we will explain two here: the safari design and the freeform design.

SAFARI

The safari design is characterised by relatively few poles and more clamps. On the one hand there is a clamp at the top of each side pole*. There is also a clamp mounted on the canvas on the reverse sides of the pole. The tension straps/ropes of all three clamps are pulled to the same anchoring point.

Each of the sides has 2 side poles.

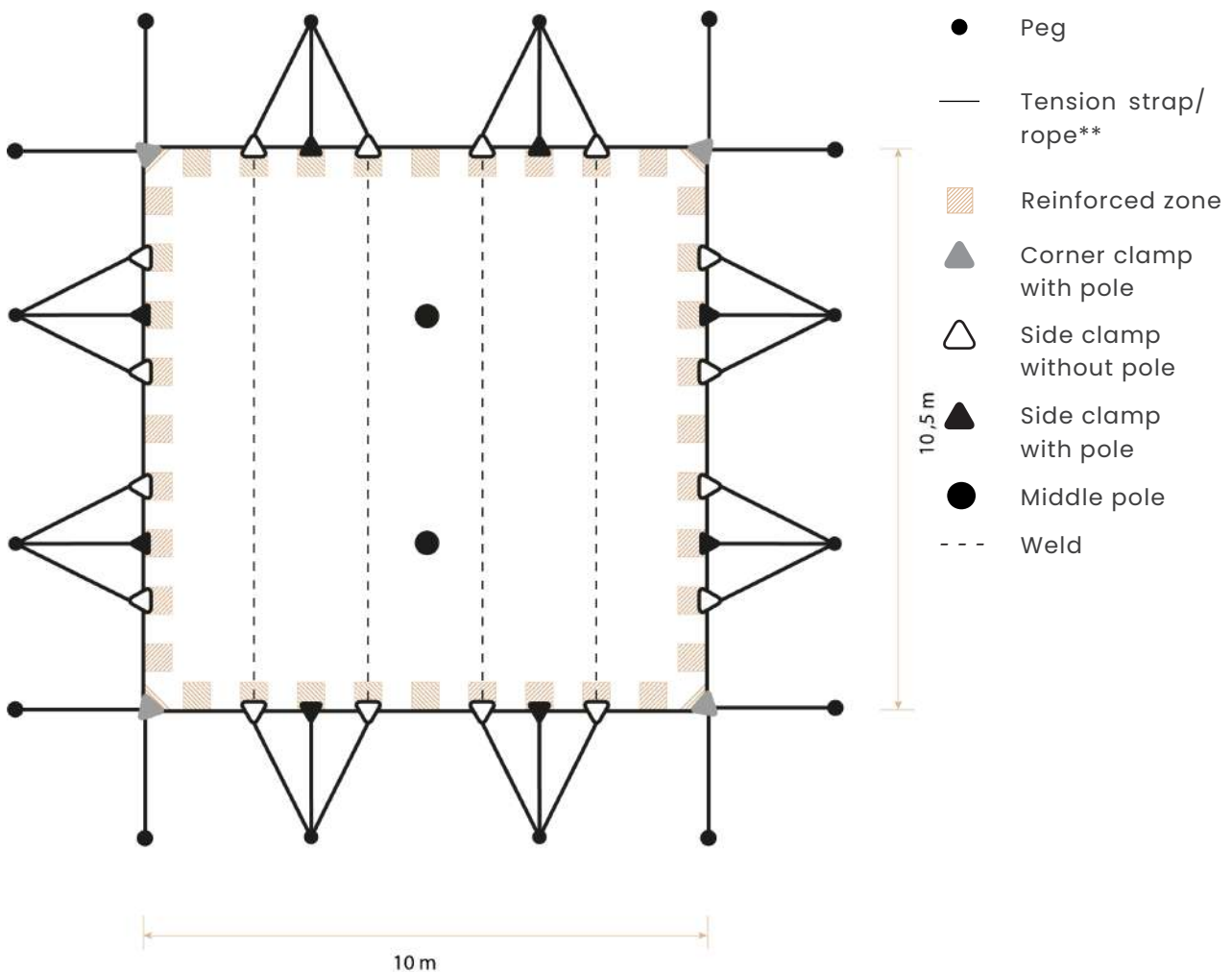

Aluminium pole: 220 cm (2 x 110 cm) - Wooden pole: 240 cm

Aluminium pole: 270 cm (2 x 110 cm + 1 x 50 cm) - Wooden pole: 280 cm

Aluminium pole: 440 cm (4 x 110 cm) - Wooden pole: 420 cm

* If the poles are placed outside the canvas, the instructions must be followed for the use of an eyebolt with threaded rod in step 1.1.1 (use of wooden poles) and step 1.2.2 (use of aluminium poles.)

** Recommended length = pole length

FREEFORM

One of the advantages of the Bonga stretch tent is the freedom of design. In addition to the two regular design options, you can let your creativity go wild and even experiment with the design; open sides, closed sides, a combination of both, part safari design, part standard design - the sky is the limit. Even when the tent has already been erected, you can easily change the configuration by adding or removing poles or clamps!

Please find below a few tips & tricks to be aware of:

- » Ensure sufficient water run-off. That is to say, there must be sufficient difference in levels between the centre and side poles. This prevents the formation of water pockets and protects the integrity of the tent.
- » Always place the side clamps on the reinforced zones. If you do not do this, the internal trapeze cord may be torn away from the canvas.
- » For tents with a width of 10 metres and over we recommend the use of 400 to 440 cm centre poles.
- » Use the supplied small pole caps to distribute the tension better by the addition of extra pressure points. If you want to close the side walls, you can use the small pole caps to reduce the level difference by tensing the canvas gradually lower to the ground.



bonga

Europalaan 83
9800 Deinze

sales@bongastretchtent.com